

**AT A GLANCE**

**FEATURES**

- Optional trim switch(es)
- Drag and detent adjustment standard
- Works on 12v and 24v systems
- Up to four engine capability
- Light coded diagnostic information
- Utilizes standard 33c type control cables – TFXtreme type recommended
- Full power train synchronization standard on multi-engine applications
- Built-in start in-gear protection
- Neutral warm-up
- Mechanical override “get home” feature
- Meets or exceeds all applicable standards



## i6300 ELECTRONIC CONTROL SYSTEM

### TECHNICAL DATA

The new i6300 delivers precise control of a boat’s shift and throttle functions, thanks to Teleflex’s responsive and robust Shift and Throttle Actuators. Works on 12 or 24V systems. The actuators are linked to the control head with a single 1/4” CANbus cable — for easy routing and installation. With a single small cable connecting all control stations to the smart actuators, there is no longer a need for heavy, complex wiring harnesses associated with other electronic control systems. All i6300 system kits come with all components needed for an installation, including power cables, power module, and network cable.

### APPLICATIONS

- Suitable for all engines with mechanical shift and mechanical throttle
- Single, Twin, Triple and Quad engine combinations
- Inboards, IO’s and Outboards
- Unlimited additional stations

i6300 COMPLETE SYSTEMS		ADDITIONAL STATIONS
i6311	Single Engine	i6311A
i6351	Single Engine with TRIM	i6351A
i6312	Dual Engine	i6312A
i6352	Dual Engine with TRIM	i6352A
i6313	Triple Engine	i6313A
i6353	Triple Engine with TRIM	i6353A
i6314	Quad Engine	i6314A
i6354	Quad Engine with TRIM	i6354A



**INFORMATION REQUIRED TO SPEC A SYSTEM**

Number of Engines (1,2,3 or 4)

Number of Stations

Trim Switch Required (yes or no)

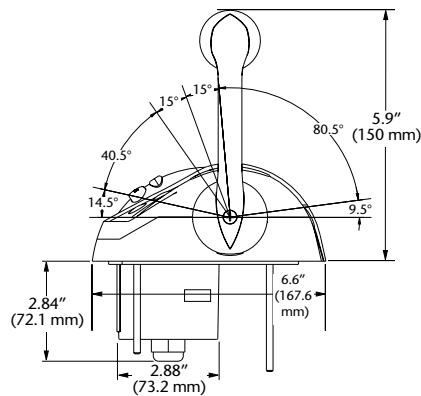
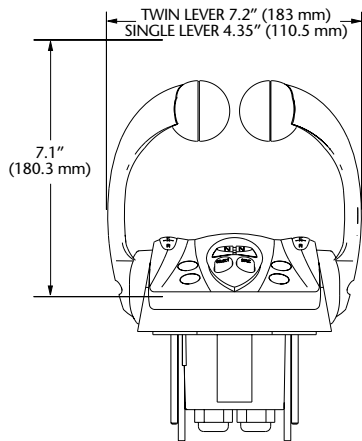

**SHIFT AND THROTTLE ACTUATOR**

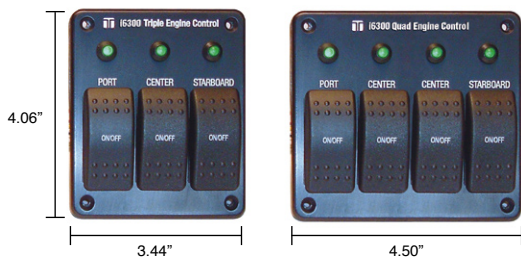
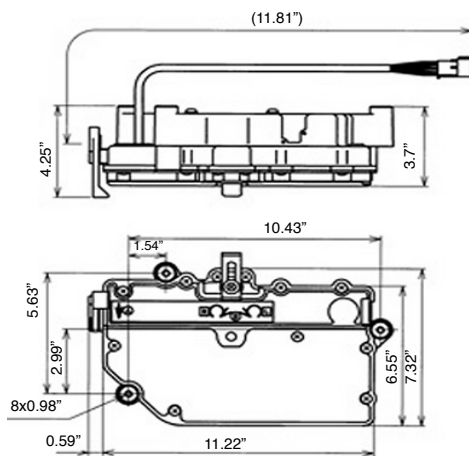

With the triple and quad engine switches, the operator can neutralize the center engine(s) for easier docking and improved maneuverability.



SINGLE STATION / SINGLE ENGINE

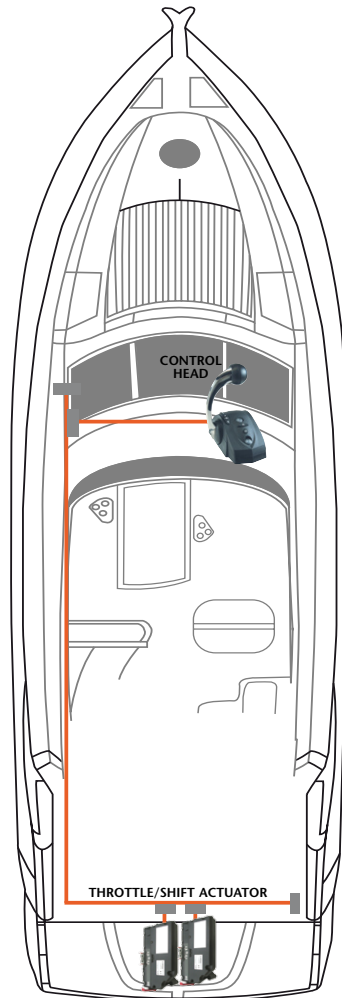

DUAL STATION / DUAL ENGINE

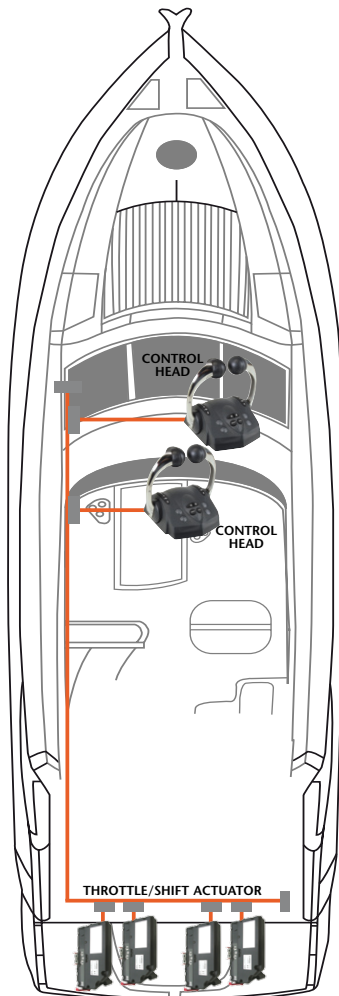

SINGLE STATION / TRIPLE ENGINE

